

10/20/30/40 AC Output Solid State Relay/Output Module

PCS55



FEATURES

- DC or AC Control
- Back to Back SCR Output Design
- LED Status Indicator
- Photoelectric Isolation
- Built in RC Snubber Circuit
- Heatsink Integrated
- 35 mm DIN Rail or Panel Mounted

INPUT PARAMETERS (Ta = 25°C)

cULus E93379

Control Voltage Range	DC Input	4 VDC - 32 VDC
	110 VAC Input	90 VAC - 140 VAC
	220 VAC Input	180 VAC - 280 VAC
	24 V Input	19.2 - 28.8 VDC / VAC
Must Turn-On Voltage	DC Input	4 VDC
	110 VAC Input	90 VAC
	220 VAC Input	180 VAC
	24 V Input	19.2 VDC / VAC
Must Turn-Off Voltage	DC Input	1 VDC
	110 VAC Input	10 VAC
	220 VAC Input	10 VAC
	24 V Input	2 VDC / VAC
Max. Input Current		25 mA
Reverse Protection Voltage	DC Input	-32 VDC

OUTPUT PARAMETERS (Ta = 25°C)

Rated Load Current	10 A	20 A	30 A	40 A
Load Voltage Range	240 A	48 VAC - 280 VAC		
	480 A	48 VAC - 530 VAC		
	600 A	48 VAC - 660 VAC		
Max. Transient Overvoltage	240 A	600 Vpk		
	480 A	1,200 Vpk		
	600 A	1,600 Vpk		
Rated Load Current	10 A	20 A	30 A	40 A
Max. Surge Current (10 ms)	160 Apk	250 Apk	700 Apk	1,000 Apk
Max I ² t for Fusing (10ms, A ² s)	128	1,250	2,450	5,000
Min. Load Current	100 mA			
Max. Off-state Leakage Current	10 mA			
Max. On-state Voltage Drop	1.6 Vrms			
Max. Turn-on Time	DC Input (Zero)	1/2 Cycle + 1 ms		
	DC Input (Random)	1 ms		
	110 VAC Input	20 ms		
	220 VAC Input	20 ms		
	24 V Input	20 ms		
Max. Turn-off Time	DC Input	1/2 Cycle + 1 ms		
	110 VAC Input	40 ms		
	220 VAC Input	40 ms		
	24 V Input	40 ms		
Frequency Range	47 H - 63 Hz			
Min. Power Factor	0.5			
Min. Off-state dv/dt	500 V/μs			

CROSS REFERENCES

Weidmüller PSSR
PSSR 24VDC/1PH AC25A Order No. 1406200000 crosses to PCS55D-240A-20Z
PSSR 24VDC/1PH AC 22A I Order No. 2531050000 crosses to PCS55D-480A-30R
PSSR 24VDC/1PH AC 35A Order No. 1406210000 crosses to PCS55D-480A-30Z
PSSR 230VAC/1PH AC 25A Order No. 1406220000 crosses to PCS55-220A-240A-20Z

ORDERING INFORMATION

Example:	PCS55	-110A	-240A	-20	Z
Model:	PCS55				
Control Voltage:	D: 4 - 32 VDC; 110A: 90 - 140 VAC 220A: 180 - 280 VAC; 24: 19.2 - 28.8 VDC / VAC				
Load Voltage:	240A: 48 - 280 VAC; 480A: 48 - 530 VAC; 600A: 48 - 660 VAC				
Load Current:	10: 10 Amp; 20: 20 Amp; 30: 30 Amp; 40: 40 A				
Switching Type:	Z: Zero Crossing, R: Random Turn-On				
Housing:	Nil: Screw Terminal S: Spring Terminal				

Box Quantity: XXX; Inner Box YYY

CHARACTERISTICS

Dielectric Strength	4,000 VAC, 1 minute, Input/Output
	2,500 VAC, 1 minute, Input/Output - Base
Insulation Resistance	1,000 MΩ at 500 VDC
Operating Temperature	- 30°C to 80°C
Storage Temperature	- 30°C to 100°C
Weight	170g (10A), 240g (20A/30), ~360g (40A)

The use of the PCS55 with an AC Voltage Surge load greater than the rated voltage is possible with the use of a varistor for transient voltage suppression. For 220VAC applications, a 470 VAC varistor is recommended. For 380VAC applications, a 750 VAC varistor is recommended. For 480VAC applications, a 1,100 VAC varistor is recommended.

PRECAUTIONS

1. A relay is a power device and thus a minimum of 20 mm of ventilation space is required between relays and surrounding components
2. Install the relays so they are adequately ventilated. If poor ventilation is unavoidable, the load current must be reduced. Please refer to the table "Load Current vs Ambient Temperature" for Maximum Current Ratings. In no case should the maximum temperature be allowed to exceed 80°C.
3. Ground the rail or heatsink
4. Select required screw driver and wire to connect relay; requirements are as follows:

		Input Terminal (3,4)		Load Terminal (1,2)
		Screw type	Spring type	Screw type
Screwdriver Specifications		Straight, 0.6x3.5mm	-	Cross 2#, 0.8x5.5mm
Recommended Torque		0.6N*m	-	1N*m
Stripping Length		7cm	10cm	10cm
Optional Wire	Single core Cable	1x0.5 ~ 2.5mm ² 2x0.5 ~ 1mm ²	1x0.5 ~ 2.5mm ²	2x1.5 ~ 6mm ²
	Multi-core cable (with ferrule)	1x0.5 ~ 2.5mm ² 2x0.5 ~ 1mm ²	1x0.5 ~ 2.5mm ²	1x1.5 ~ 10mm ² 2x1.5 ~ 6mm ²
AWG		1x20 to 12		2x14 to 10

5. Do not use the relay beyond the parameters listed in this data sheet
6. The input circuitry does not incorporate a circuit protecting the SSR from being damaged due to a reversed connection. Make sure that the polarity and the input and output are correct when connecting.
7. When using the relay in phase control applications, at a phase control angle close to 180 degrees the relay's input signal will turn off at the trailing edge of the AC sine wave. The phase delay must be limited to end 200us before AC zero cross. This assures that the relay has time to switch off. Shorter times may cause loss of control at the following half cycle.

DIMENSIONS Inches (mm)

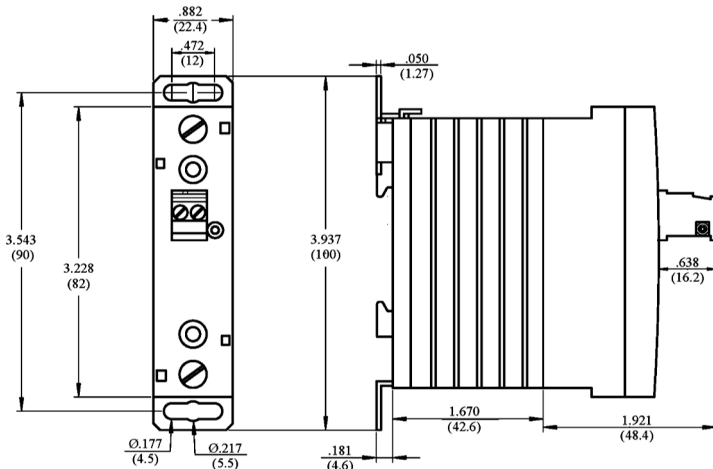

10 Amp

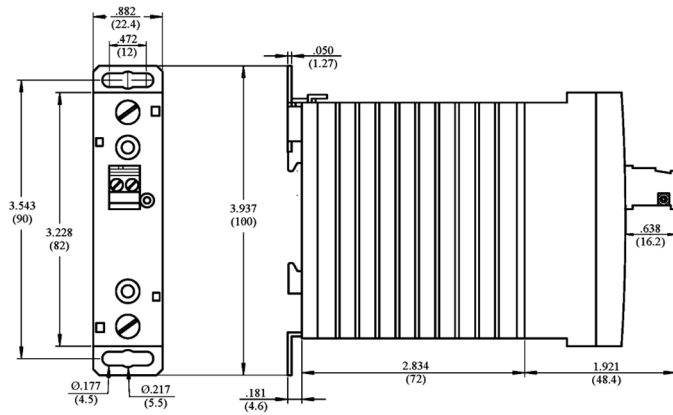

20 & 30 Amp

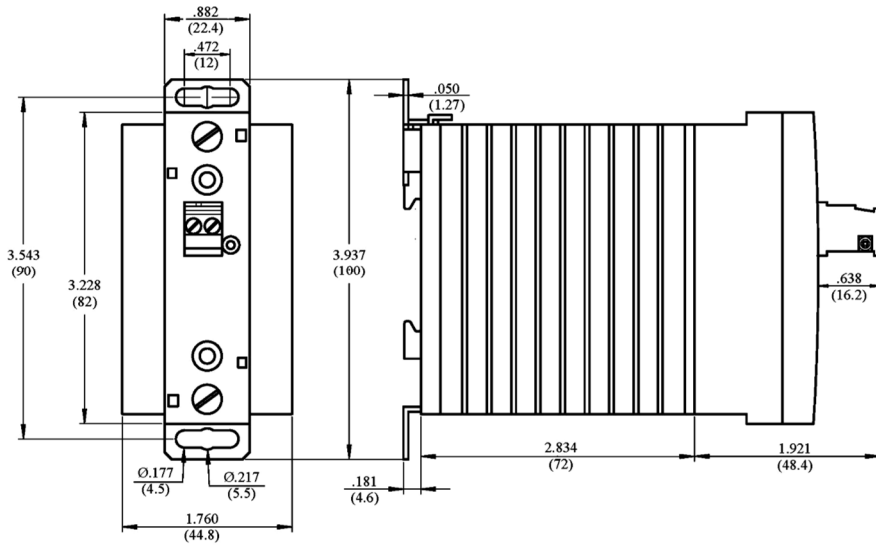

40 Amp

CHARACTERISTIC CURVES

Load Current vs. Ambient Temperature

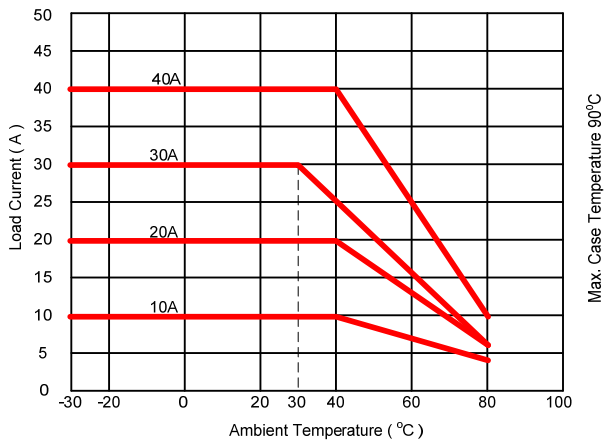

Mounting Diagrams

Dimensions Installation diagram Unit:mm

